

Right-of-Way Permit

Permit No. _____

Public Utility/Owner Name: _____

Mailing Address: _____

Contact Person: _____

Phone: _____ Fax: _____ Mobile: _____

Application Date (mm/day/year): _____

Township: _____ Road Name/Number: _____

Description of work to be performed within the right-of-way:

Type of Utility: Gas Electric Phone Cable Water Sewer Other: _____

- 1. Overhead Line Parallel to Road
- 2. Overhead Line Crossing Road
- 3. Underground (buried) Line Parallel to Road
- 4. Underground (buried) Line Crossing Road
- 5. Utility Pole Installation
- 6. Other (please describe): _____

If No. 3 or 4, denote open cut or boring request: open cut boring

Details for work to be performed:

Beginning Project Location (specify distance from nearest intersection and side of road):

Ending Project Location (specify distance from nearest intersection and side or road):

Estimated start date and completion date (mm/day/year): start _____ completion _____

Work Provisions

I, the undersigned, understand that the Board of Trustees, Newton Township, Muskingum County assumes no responsibility or liability for the work done under this permit and that all work shall be done at no cost to the County. All work shall be done as applicable, in accordance with the State of Ohio Department of Transportation Construction and Materials Specifications, the Ohio Manual of Uniform Traffic Control Devices, and any supplemental and special provisions deemed necessary or as stated on the permit as special provisions or conditions. The Board of Trustees reserve the right to order the removal, reconstruction, relocation, or repair of any work performed under a permit at the owner's expense. The township reserves the right to appoint an inspector over the work. I hereby agree to all terms, conditions, general provisions attached hereto and restrictions so far as they apply to work to be done under the permit as issued.

Public Utility Agent/Owner

Signature of Utility Agent/Owner

Date

AUTHORIZED:

Board of Township Trustees
Newton Township

GENERAL PROVISIONS

Right-of-Way Permit

Permit holder shall meet the following provisions prior to and during the proposed work unless otherwise specifically approved by Newton Township:

1. The township shall be notified not less than Two (2) Days prior to the start of work, by contacting the fiscal officer or trustees. Affected property owners within the construction area shall be notified within two (2) working days prior to the commencement of work.
2. Crossing an asphalt or concrete roadway shall be by boring at a minimum depth of 36 inches, unless the twp specifically approves an open cut request in writing.
3. **Open Cut, if approved**, – Concrete or Asphalt Roads shall be cut by saw. Trenches shall be a minimum of 36 inches in depth. Utility Lines shall be within a steel casing. Trenches shall be backfilled to the road surface with five (5) sack control density fill (CDF) material. Steel plates are recommended to open the road to traffic while CDF has time to set up. During the next immediate paving season, an asphalt patch will be placed on the full width of the roadway, 1.5 inches in thickness, and extending for a total of 50 feet or 25 feet either side of the trench.
4. When placing utilities along the road, they must be placed a minimum of 36 inches below the ditch line.
5. All utilities shall be installed along the outside edge of the road shoulder or be a minimum of four (4) feet from the edge of the paved surface whichever is greater. The utility line shall not be placed closer than ten (10) feet from any part of a culvert, bridge, or wingwall, unless specific written permission is granted by the township.
6. Should the road, structures, or any public property become damaged from this operation, the named permit holder is responsible for the cost of repair or replacement to the condition before work began.
7. Drainage ditches shall be opened and restored at the completion of line installation or other type of work.
8. Bridge load limits shall be observed when encountered along a route or traveling to a location.
9. Trenches within four (4) feet of the edge of pavement or road surface, if approved, shall be thoroughly compacted with granular backfill and the shoulder restored in as good a condition as prior to the installation. Ditches shall be restored to the same shape and depth of those adjacent to the work and seeded and mulched.
10. No dirt or other materials shall be placed on the road. It is preferred that the road be completely clear of all debris at end of each day's operation.
11. **All safety precautions necessary to workers and the traveling public shall be taken.** Flag persons and proper traffic control shall be provided at all times including but not limited to proper color, shape and size. When necessary, reflective signs, barricades, flags or stop and go paddles shall be utilized for proper traffic control.
12. Traffic will be maintained at all times, unless permission is granted by the township to close the road. The permit holder shall notify the county five (5) working days prior to the close of a road, if the township approves such closure, and provide a firm start date and completion date, including estimated times of day for the construction period.

13. The permit holder agrees to relieve the County of Muskingum, Newton Township, and all their agents and employees of all liability or damages and accident claims arising as a result of construction or future township maintenance.
14. The permit holder agrees to locate their facility in accordance with the Ohio Revised Code, Utility Protection Laws, and shall remove, relocate, expose, or otherwise protect their facilities located within the public rights of way of Muskingum County for highway maintenance or improvements at no cost to the county. The permit holder shall call the Ohio Utilities Protection Service at 1-800-362-2764 two (2) days prior to construction. Non-member utilities must be contacted directly.
15. The permit holder shall provide a sketch of location or attach drawings for the work to be performed.
16. All provisions set forth above shall govern with the exception of any specific conditions outlined on "Schedule A" attached to this permit. If any provisions of "Schedule A" and the general provisions of this permit are in conflict, the provisions set forth on "Schedule A" shall govern and take precedence.

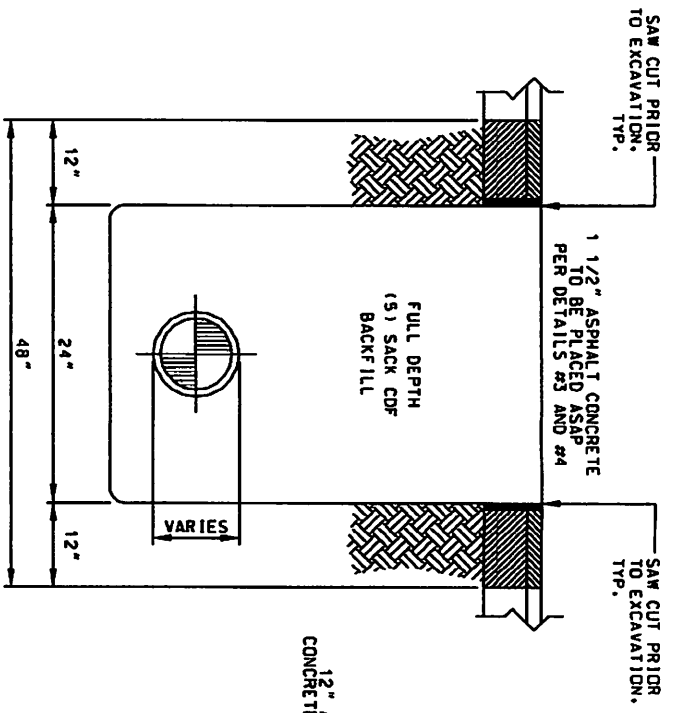

TYPICAL ROAD CROSSING - DETAIL#2

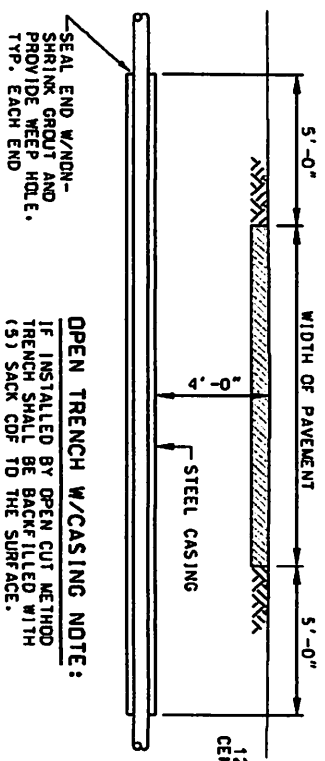

TYPICAL ROAD CROSSING - DETAIL#1

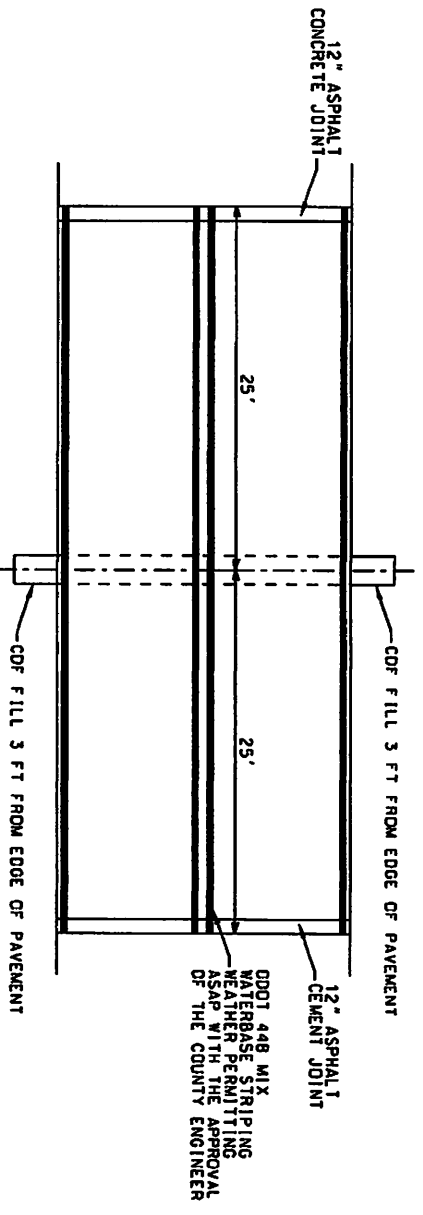

TYPICAL ROAD CROSSING - DETAIL#3

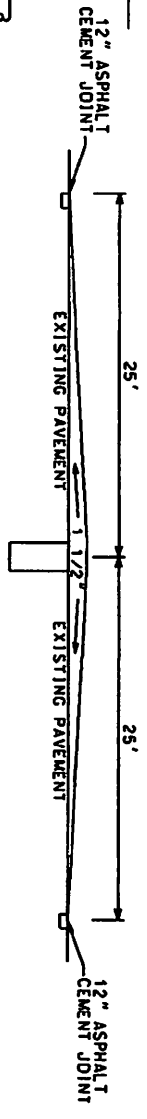

TYPICAL ROAD CROSSING - DETAIL#4